

Specifications

16JNK Landex

Internally Tripped Die Head

[1/2" JN Landex Chaser Holders](#)

The 16JNK Internally Tripped Die Head simultaneously threads, reams, and chamfers pipe.

A reaming attachment, operating internally and connected to the head trip spyder, can be adjusted to obtain the desired thread length.

The reamer acts as a stop bar for the internal trip mechanism and assures that constant repetitive thread length is produced regardless of the nipple length or gripping position.

Similar in design to the T Type Lanco Internally Tripped Head, the 16JNK is primarily for application to Landis 16DEN double end and 16-20B threading machines.

The head can also be adapted to 582A and 792A Oster threaders.

Range: 1/8" to 2" NPT, NPSM, BSTP and BSPP pipe threads.

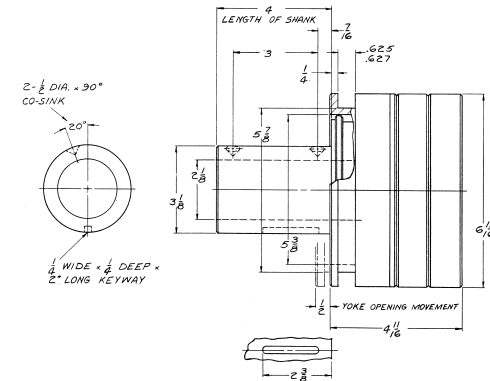
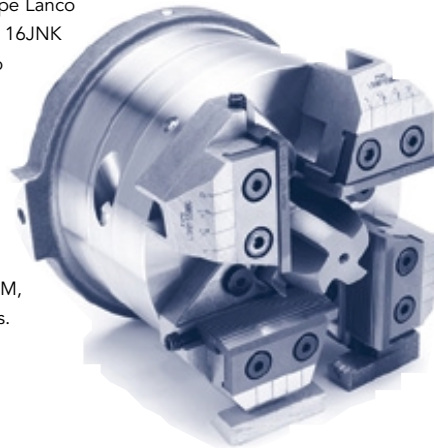

1/2 JN LANDEX – Standard Chaser HoldersK

RANGE	THREAD FORM	HELIX ANGLE	CHASER SIZE	RIGHT-HAND		LEFT-HAND	
				HOLDER PART NO.	GAGE PART NO.	HOLDER PART NO.	GAGE PART NO.
1/8 to 3/4	Taper Pipe	1-3/4°	15/16 x 2-1/8	LNS015579G1	L016099	–	–
1/2 to 3/4	Taper Pipe	1-3/4°	15/16 x 2-1/8	LNS015579G	L016099	–	–
1/4 to 3/4	Taper Pipe	1-3/4°	15/16 x 2-1/8	LSX015579G	L016099	LNS019728G	LNS019729
1 to 2	Taper Pipe	1°	1-1/4 x 2-3/4	LSX015580G	L016100	LNS019102G	LNS019103
1/8 to 3/4	STR Pipe	1-3/4°	15/16 x 2-1/8	LNS019737H1	L0D007109	–	–
1/2 to 3/4	STR Pipe	1-3/4°	15/16 x 2-1/8	LNS019737H2	L0D007109	–	–
1/4 to 3/4	STR Pipe	1-3/4°	15/16 x 2-1/8	LNS019737H	L0D007109	LNS019760H	LNS0D007110
1 to 2	STR Pipe	1°	15/16 x 2-1/8	LNB091657H	L0D013394	LNSOC091826H	LNSOD069344

K Chaser holder and chaser setting gage numbers that have the "L" prefix indicates that they are stocked items. Numbers that are preceded by the "LNS" prefix indicates that they are non-stock items.